

# INDUSTRIAL BELT HOPPER

## VARIANTS

|                      |   |
|----------------------|---|
| Fill Volume:         | 5, 10, 25, 30, 50 and 70 litres   |
| Belt body:           | with aluminium profile, red anodized bearing brackets                                 |
| Hopper bowl:         | made of stainless steel   |
| Belt type:           | smooth two-layers PU with or without v-guides (FDA approved),<br>Supergrip (textured) |
| Drive kits           | various options (view table)  |
| Customized versions: | <b>upon request</b>   |

## DIMENSIONS

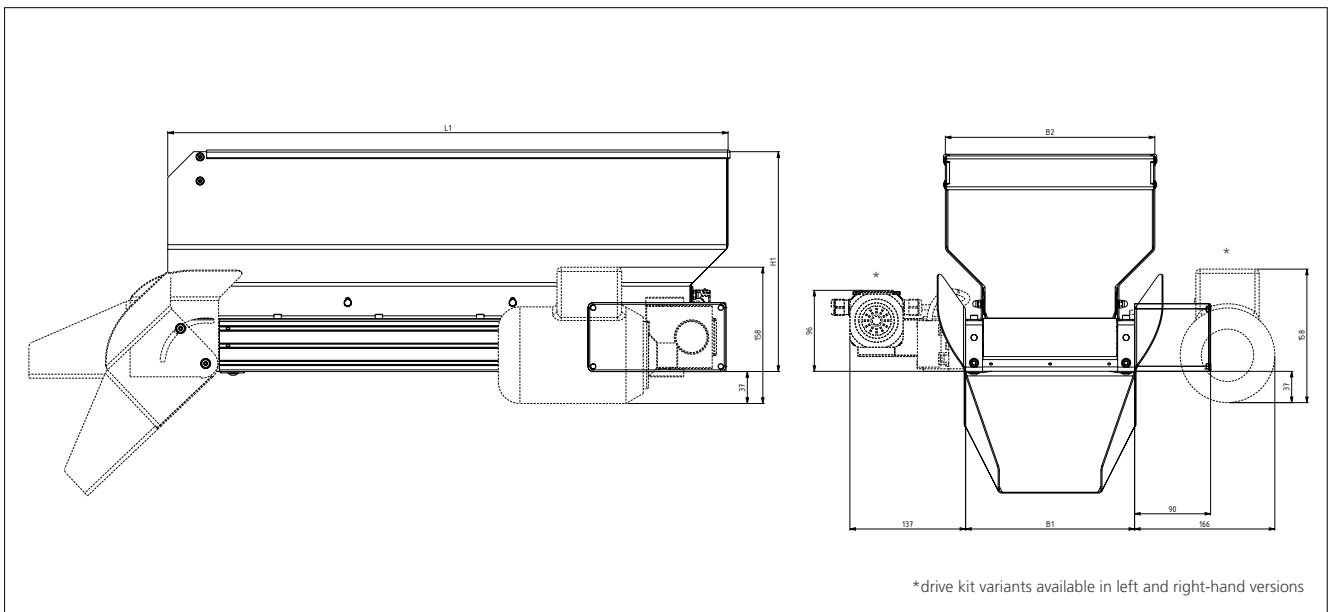

| Type  | Nominal volume [Litres] | L1* [mm] | B1* [mm] | B2* [mm] | H1* [mm] |
|-------|-------------------------|----------|----------|----------|----------|
| HBB05 | 5                       | 371      | 152      | 200      | 184      |
| HBB10 | 10                      | 458      | 200      | 248      | 211      |
| HBB25 | 25                      | 650      | 200      | 248      | 255      |
| HBB30 | 30                      | 650      | 200      | 248      | 360      |
| HBB50 | 50                      | 710      | 252      | 390      | 414      |
| HBB70 | 70                      | 912      | 252      | 390      | 410      |

## DRIVE OPTIONS

|                                      | HBB05                 | HBB10                 | HBB25                 | HBB30                 | HBB50                 | HBB70                 |
|--------------------------------------|-----------------------|-----------------------|-----------------------|-----------------------|-----------------------|-----------------------|
| <b>Nominal volume</b>                | 5 l                   | 10 l                  | 25 l                  | 30 l                  | 50 l                  | 70 l                  |
| <b>Device weight</b>                 | 14 kg                 | 19 kg                 | 20 kg                 | 22 kg                 | 24 kg                 | 32 kg                 |
| <b>24 VDC Standard</b>               | 3W/0,1A               | 3W/0,1A               | 3W/0,1A               | 3W/0,1A               |                       |                       |
| Conveyor speed                       | 0,13 m/min            | 0,13 m/min            | 0,13 m/min            | 0,13 m/min            | on request            | on request            |
| Fill weight                          | 20 kg                 | 20 kg                 | 20 kg                 | 20 kg                 |                       |                       |
| <b>1 x 230V 50Hz Standard</b>        | 3,5W/0,02A            | 3,5W/0,02A            | 3,5W/0,02A            | 3,5W/0,02A            |                       |                       |
| Conveyor speed                       | 0,13m/min             | 0,13m/min             | 0,13m/min             | 0,13m/min             | on request            | on request            |
| Fill weight                          | 20 kg                 | 20 kg                 | 20 kg                 | 20 kg                 |                       |                       |
| <b>1 x 230V/ 50Hz Heavy duty</b>     | 0,09kW / 1A           | 0,09kW / 1A           | 0,09kW / 1A           | 0,09kW / 1A           | 0,09kW / 1A           | 0,09kW / 1A           |
| Conveyor speed                       | 1,8 m/min / 2,2 m/min | 1,8 m/min / 2,2 m/min | 1,8 m/min / 2,2 m/min | 1,8 m/min / 2,2 m/min | 1,8 m/min / 2,2 m/min | 1,8 m/min / 2,2 m/min |
| Fill weight                          | 60 kg                 | 60 kg                 | 60 kg                 | 60 kg                 | 60 kg                 | 60 kg                 |
| <b>3 x 230V/400V 50Hz Heavy duty</b> | 0,05kW / 0,4A         | 0,05kW / 0,4A         | 0,05kW / 0,4A         | 0,05kW / 0,4A         | 0,05kW / 0,4A         | 0,05kW / 0,4A         |
| Conveyor speed                       | 1,8 m/min / 2,2 m/min | 1,8 m/min / 2,2 m/min | 1,8 m/min / 2,2 m/min | 1,8 m/min / 2,2 m/min | 1,8 m/min / 2,2 m/min | 1,8 m/min / 2,2 m/min |
| Fill weight                          | 60 kg                 | 60 kg                 | 60 kg                 | 60 kg                 | 60 kg                 | 60 kg                 |
| <b>24 VDC Flexible</b>               | 36-60W / 1,5-2,5A     | 36-60W / 1,5-2,5A     | 36-60W / 1,5-2,5A     | 36-60W / 1,5-2,5A     | 36-60W / 1,5-2,5A     | 36-60W / 1,5-2,5A     |
| Conveyor speed                       | 1,1 - 7,6 m/min       | 1,1 - 7,6 m/min       | 1,1 - 7,6 m/min       | 1,1 - 7,6 m/min       | 1,1 - 7,6 m/min       | 1,1 - 7,6 m/min       |
| Fill weight*                         | 30-60 kg              | 30-60 kg              | 30-60 kg              | 30-60 kg              | 30-60 kg              | 30-60 kg              |
| <b>1 x 230V 50Hz Flexible</b>        | 60W / 0,3A            | 60W / 0,3A            | 60W / 0,3A            | 60W / 0,3A            | 60W / 0,3A            | 60W / 0,3A            |
| Conveyor speed                       | 1,1 - 7,6 m/min       | 1,1 - 7,6 m/min       | 1,1 - 7,6 m/min       | 1,1 - 7,6 m/min       | 1,1 - 7,6 m/min       | 1,1 - 7,6 m/min       |
| Fill weight*                         | 30-60 kg              | 30-60 kg              | 30-60 kg              | 30-60 kg              | 30-60 kg              | 30-60 kg              |
| <b>3 x 230V/400V 50Hz Flexible</b>   | 60W / 0,15A           | 60W / 0,15A           | 60W / 0,15A           | 60W / 0,15A           | 60W / 0,15A           | 60W / 0,15A           |
| Conveyor speed                       | 0,95 - 7,6 m/min      | 0,95 - 7,6 m/min      | 0,95 - 7,6 m/min      | 0,95 - 7,6 m/min      | 0,95 - 7,6 m/min      | 0,95 - 7,6 m/min      |
| Fill weight*                         | 30 - 60 kg            | 30 - 60 kg            | 30 - 60 kg            | 30 - 60 kg            | 30 - 60 kg            | 30 - 60 kg            |

\*dependent on gear reduction ratio

## ACCESSORIES

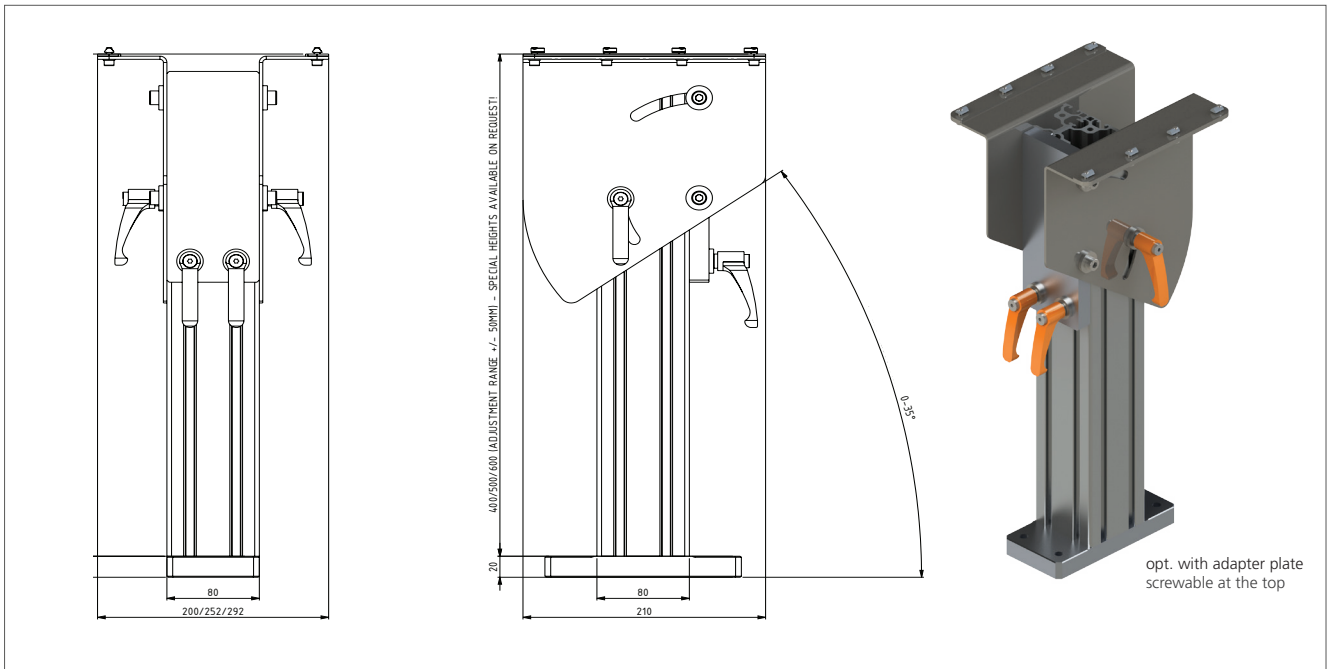

Mounting stand (adjustable angle and height)

In the range:

- >> bottom cover
- >> deflection cover
- >> quick emptying with deflection cover
- >> chute nose
- >> pc-cover with friction hinge
- >> cover lock
- >> fall brake for tipping chute
- >> protective surface for tipping chute
- >> fill level monitoring for hopper bowl

Other accessories and custom versions available upon request!

### HAMOTEK Montagetechnik GmbH

Fürstenweg 1  
83395 Freilassing  
GERMANY

Tel. +49 (0) 8654 / 770 96 63  
office@hamotek.de  
www.hamotek.de

### Assembly and manufacturing:

Eschstraße 38  
88361 Altshausen/Mendelbeuren  
GERMANY